

# HOLDER

NO COMPROMISES

## HOLDER S 990 / S 1090 BENEFITS, FEATURES AND TECHNICAL DATA



# HOLDER S 990 / S 1090



2-person cabin



1-person cabin



## CABIN

- Comfort cabin with air conditioning and 360° circumferential visibility
  - Windows can be opened on the side
  - Very spacious even for tall and big drivers
  - Air-suspended driver's seat-heating, height-adjustable and longitudinally adjustable, with longitudinal-horizontal suspension
  - Available with 1-person or 2-person cabin
  - 2-person cabin including resonating multi-functional arm rest and with full-fledged passenger seat – licensed for work application
- Perfect view of attachments and maximum working comfort**

## OPERATING CONSOLE

- 1-hand operation
  - Clear membrane keyboard
  - Programmable joystick
  - Drive program control for 4 driving and working steps with limit load control
- Individual setting options for the professional user**

## SERVICE ACCESS

- Hydraulically tiltable engine compartment cover with integrated tipping framework (incl. hitched device)
  - Removable side parts at the right and left
  - Battery for e.g. jump starting during winter is accessible from the outside
- Daily servicing work is possible without disassembling the attachments**

## FRONT ATTACHMENT

- Heavy-Duty front power lift, movable 3-dimensionally and double-acting, with vibration damping, arrester hooks adjustable from KAT I to KAT II
- Lifting power up to 2700 kg
- Up to 4 double-acting control valves (plug-in couplings are drip-free), of which 2 with floating position, simultaneous control possible
- Up to 120 l/min hydraulic power for the powering of devices
- Mechanical PTO shaft, switchable from 540 r/min to 1000 r/min

## REAR ATTACHMENT

- Double-acting rear power lift with vibration damping, arrester hooks are adjustable from KAT I to KAT II
- Lifting power up to 1570 kg
- Up to 2 double-acting control valves (plug-in couplings are drip-free)
- Up to 80 l/min hydraulic power for the powering of devices
- Mechanical PTO shaft





## OTHER BENEFITS

- Block based construction (heavier, higher power transmission)
- Stepless gear with hydrostat unit
- Dual Drive (switch from hydrostatic to mechanical drive from approx. 26 km/h) for consumption optimisation and reduction of driving noise
- Differential lock with stiff fixed drive from front to rear axle, therefore precise synchronism of all wheels
- Emergency brake for inclines for absolute safety in slopes
- Hydraulically actuated wet disc brake on all 4 wheels
- Corrosion protection: all steel components are EPD-coated, plug-in couplings in ZINi, vehicle is waxed
- Transport speed up to 40 km/h
- Official approval and homologation for road service



## 3 ATTACHMENT AREAS

- 2 standardised attachment areas (front and rear lift) as well as 3rd attachment area for hitching devices
- 1-person device mounting without tools



## STEPLESS DRIVING UP TO 40 KM /H

- No traction interruptions
- Transport: automotive driving via foot pedal
- Working: speed control via rotary potentiometer
- Alternatively, speed control via foot pedal at constant PTO shaft speed = SDS traction drive

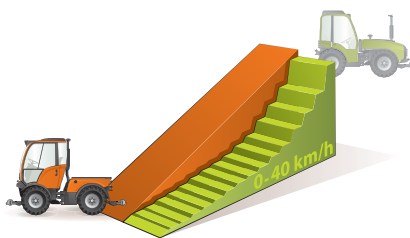

## ELECTRO-HYDRAULIC ATTACHMENT RELIEF

- Weight of the attachment can be transferred to the entire vehicle steplessly
- Due to the electro-hydraulic control, the composition of the soil is maintained optimally
- More traction on inclinations and for slippery ground, protection of the device (e.g. mulching)



## UNIQUE TECHNOLOGY

- Articulated steering
- Permanent four-wheel drive
- 4 equal-sized wheels
- Wheel load compensation
- Mechanical differential lock acting on both axles
- 4-wheel brake

For more info and user videos, visit [www.max-holder.com](http://www.max-holder.com)

## WIDE RANGE OF APPLICATION

- Mowing and grass-collecting
- Cylinder mowing and large area mowing
- Rotary and flail mulching
- Weed removal
- Scarifying and aeration
- Watering and high-pressure cleaning
- Sweeping and suction cleaning
- Lawn sweeping and synthetic turf cleaning
- Earth handling (front loader)
- Loading and transport
- Snow ploughing and snow blowing
- Snow sweeping and snow loading
- Salt spreading (with attachment, box or funnel spreader)
- Cross-country ski tracks

### FIELDS OF APPLICATION:

- Green areas and synthetic turf
- Sports grounds and golf courses
- Sidewalks, roads and public open spaces
- Underground car parks and rails

### SECTORS

- Municipalities and service providers
- Facility management
- Horticulture and landscaping
- Airports and military

With your Holder vehicle, you are able to carry out up to 3 applications at the same time!

## WITH US, YOU ARE IN GOOD HANDS

- 24 months guarantee
- 24-hour delivery of spare parts
- More than 15 years spare parts supply
- Close service network and local partners
- Long service life
- High stability of value
- Rental, financing and leasing
- Europe-wide homologation

SEE HOLDER IN ACTION:

[www.youtube.com/user/maxholdergmbh](http://www.youtube.com/user/maxholdergmbh)

## TECHNICAL DATA S 990/S 1090

S 990 = 1-person cabin  
S 1090 = 2-person cabin

<b>ENGINE</b>	Deutz 4-cylinder 4-stroke turbo diesel
Displacement	3619 cm <sup>3</sup>
Power	68 kW (92 HP)
Torque	280 Nm
Cooling	Water cooling.
Air filter	Dry air filter with acoustic warning unit.
Fuel tank capacity	82 l
Alternator	Max. 95 A / 12 V
<b>DRIVE</b>	Hydrostatic traction drive. Controlled digital-electrically. Stepless road speed control. Optional: Dual Drive. Permanent four-wheel drive. 4 wheels of the same size.
Differential lock	Mechanical at the front and rear. Simultaneously switchable electrohydraulically. Acts on both axles at 100%. Stiff fixed drive from front to rear axle.
Top speed	40 km/h
PTO shafts	Optional: power-switchable, independent mechanical PTO shaft. Can be switched together at the front and rear. Rear PTO shaft can be switched off at the gear. Front: switchable from 1000 r/min to 540 r/min. Rear: 1000 r/min.
Brakes	Hydraulically actuated wet disc brake. Acts on all 4 wheels as four-wheel brake. Electric stop brake acts on both axles.
<b>HYDRAULICS</b>	Hydraulic pump 42.5 l/min. Or: tandem pump 35 l/min + 27.5 l/min. Both optionally expandable with additional device variable displacement pump 120 l/min.
Hydraulic oil quantity	45 l
Lifting force	Front 2700 kg/rear 1570 kg
Three-point lift	Standard three-point. Arrester hook steplessly adjustable from KAT I to KAT II.
Additional control valves	High expandability, adapted for the purpose.
<b>CABIN</b>	Comfort 1- or 2-person cabin. Mechanically suspended driver's seat. 2-person cabin with full-fledged passenger seat and resonating multi-function arm rest.
Optional additional equipment	Air-suspended driver's seat incl. seat-heating. Heated front window and exterior rear-view mirror. Air conditioning and activated carbon filter.

<b>WEIGHT</b>	Including driver at 75 kg, depending on tyres and equipment.	
	<b>1-person cabin:</b>	<b>2-person cabin:</b>
Empty weight	2638–2790 kg	2885–3073 kg
Permissible total weight	4500 kg	
Permissible axle load	Front 2700 kg/ Rear 3000 kg	
Tow bar load on the trailer coupling	Max. 800 kg	
Towing capacity	Unbraked 2500 kg/ overrun braked 4500 kg	
Maximum payload	1862 kg	1615 kg
<b>DIMENSIONS</b>	Depending on tyres.	
	<b>1-person cabin:</b>	<b>2-person cabin:</b>
Wheel base	1827 mm	
Total length	3412–4111 mm	3702–4235 mm
Total height	2181–2233 mm	2233–2295 mm
Total outer width	1308–1639 mm	1320–1639 mm
Turning circle	Inside 2130 mm	
Inner flatbed dimensions	1530 x 1200 x 300 mm	

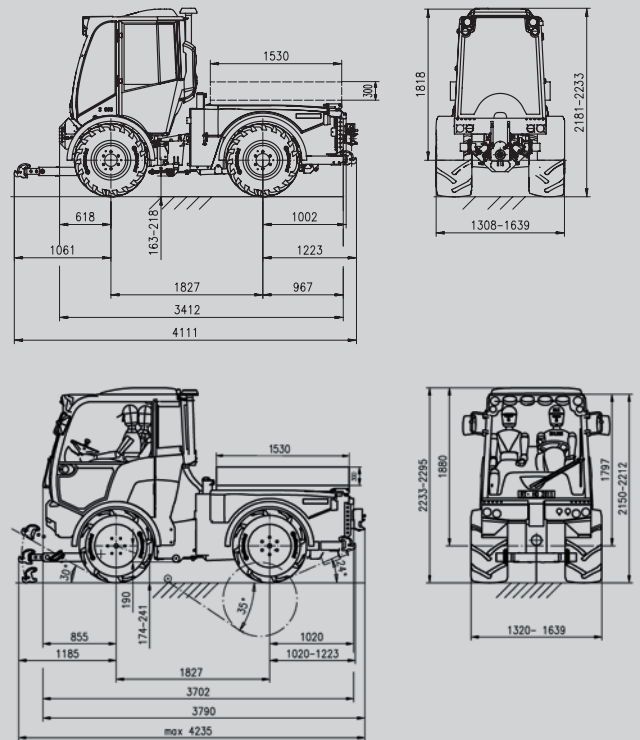

Optimum guidance, sales and service at your Holder partner:

**Max Holder GmbH**  
Max-Holder-Straße 1 | D-72555 Metzingen | Germany  
Phone: +49 7123 966-0 | Fax: +49 7123 966-213  
info@max-holder.com | [www.max-holder.com](http://www.max-holder.com)